

Response 1W/1m

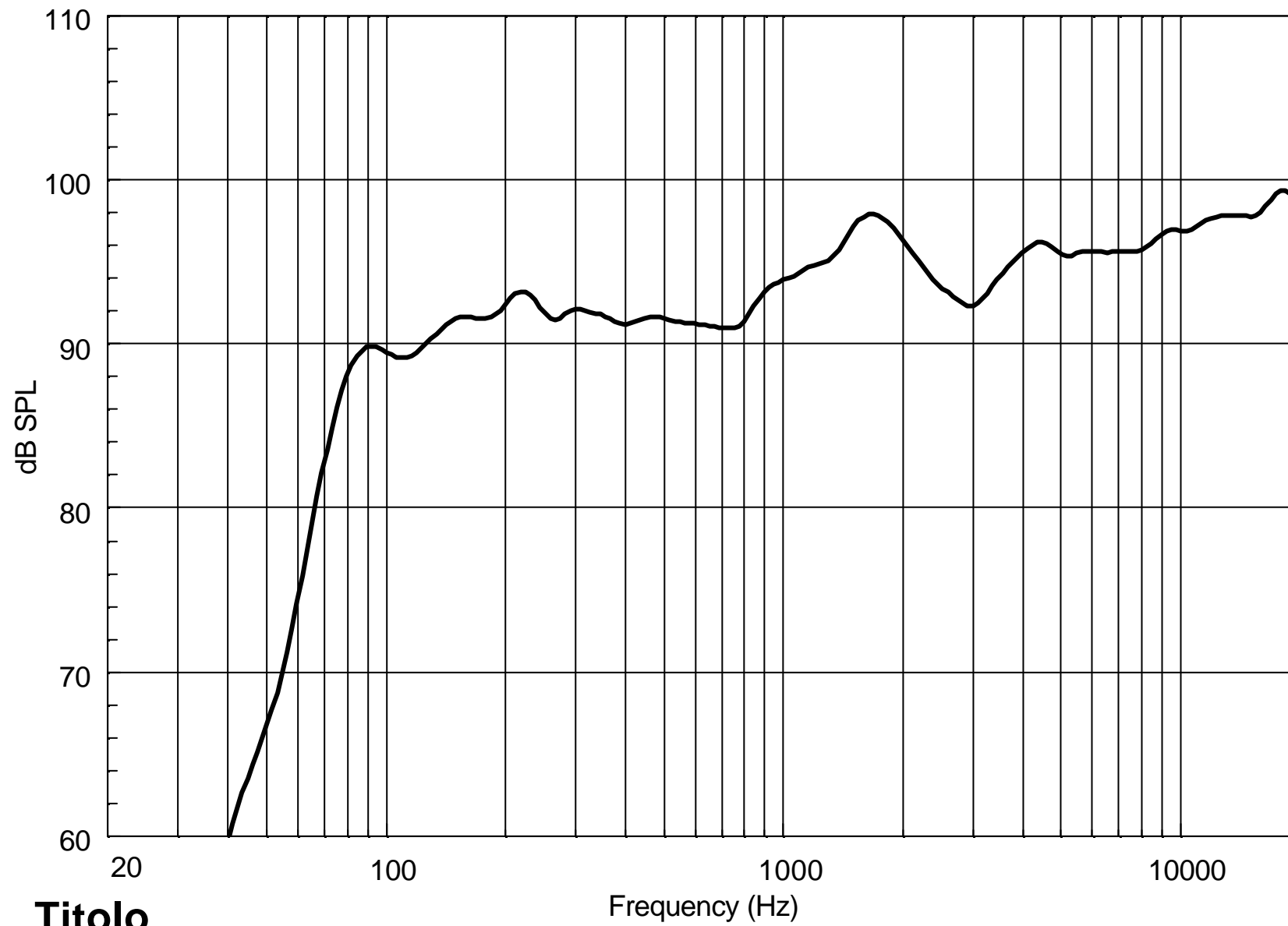

Titolo

Impedance

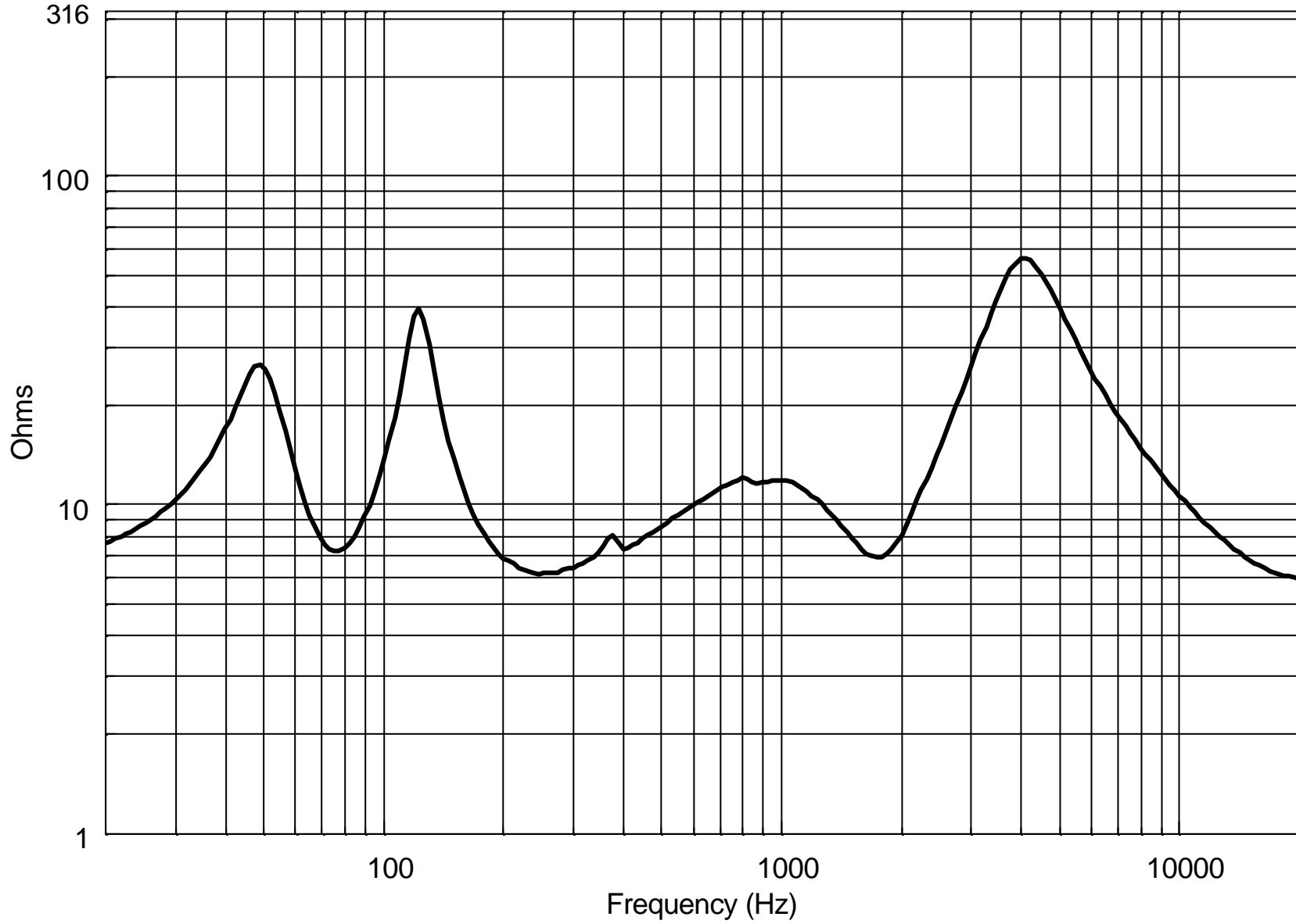

Beamwidth vs. Frequency

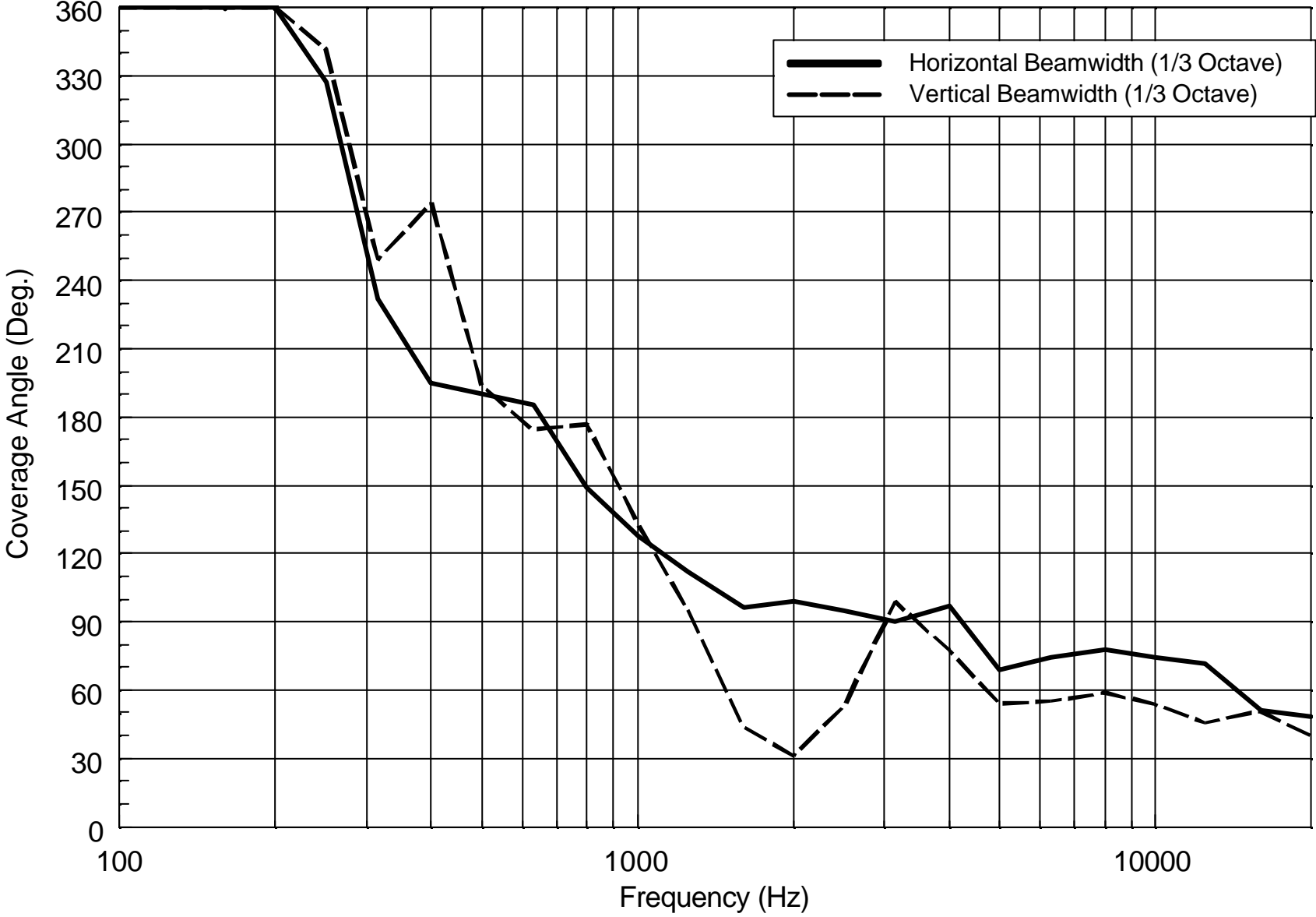

Directivity Index and Q

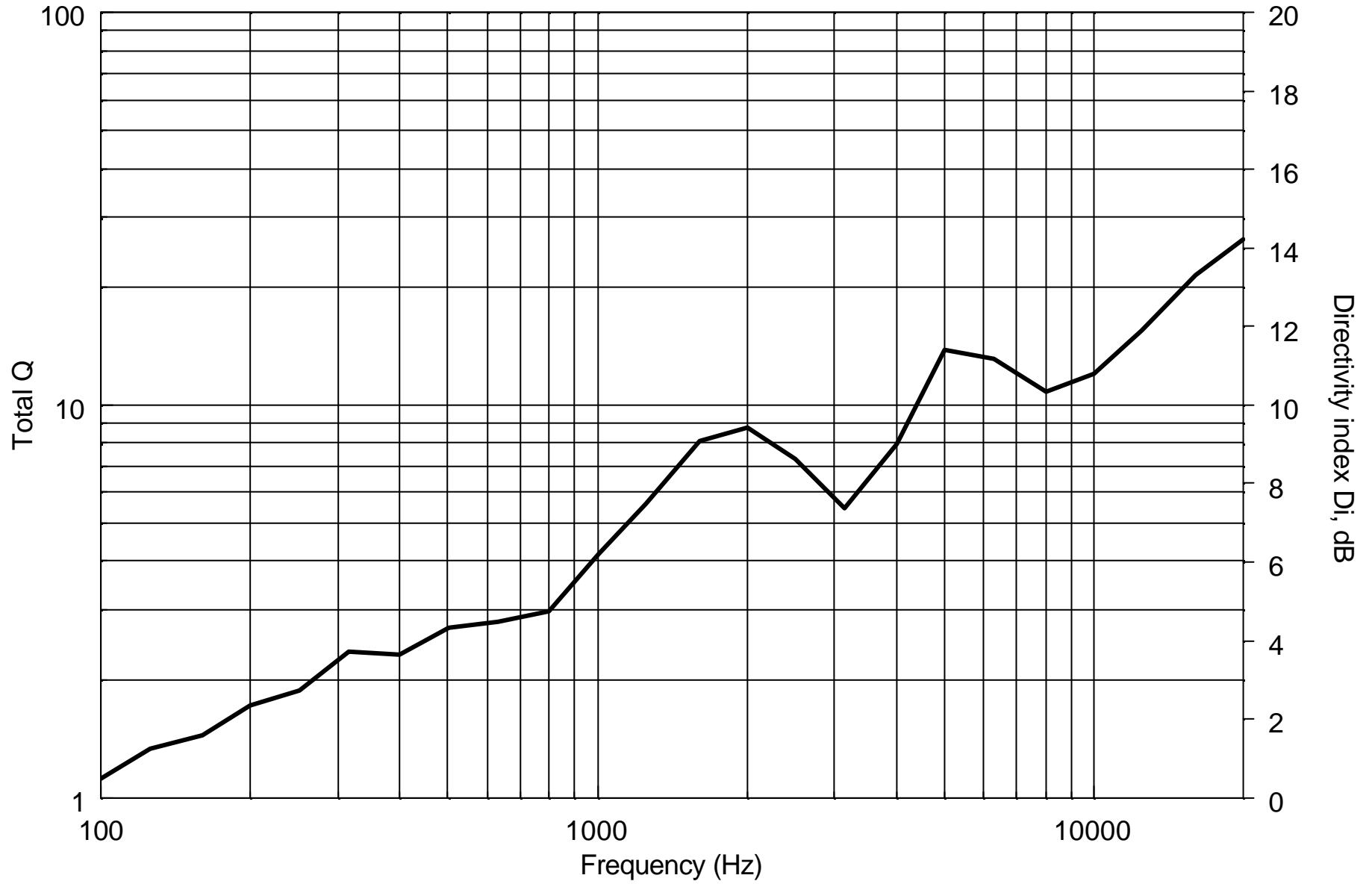

Normalized Horizontal off-axis Response

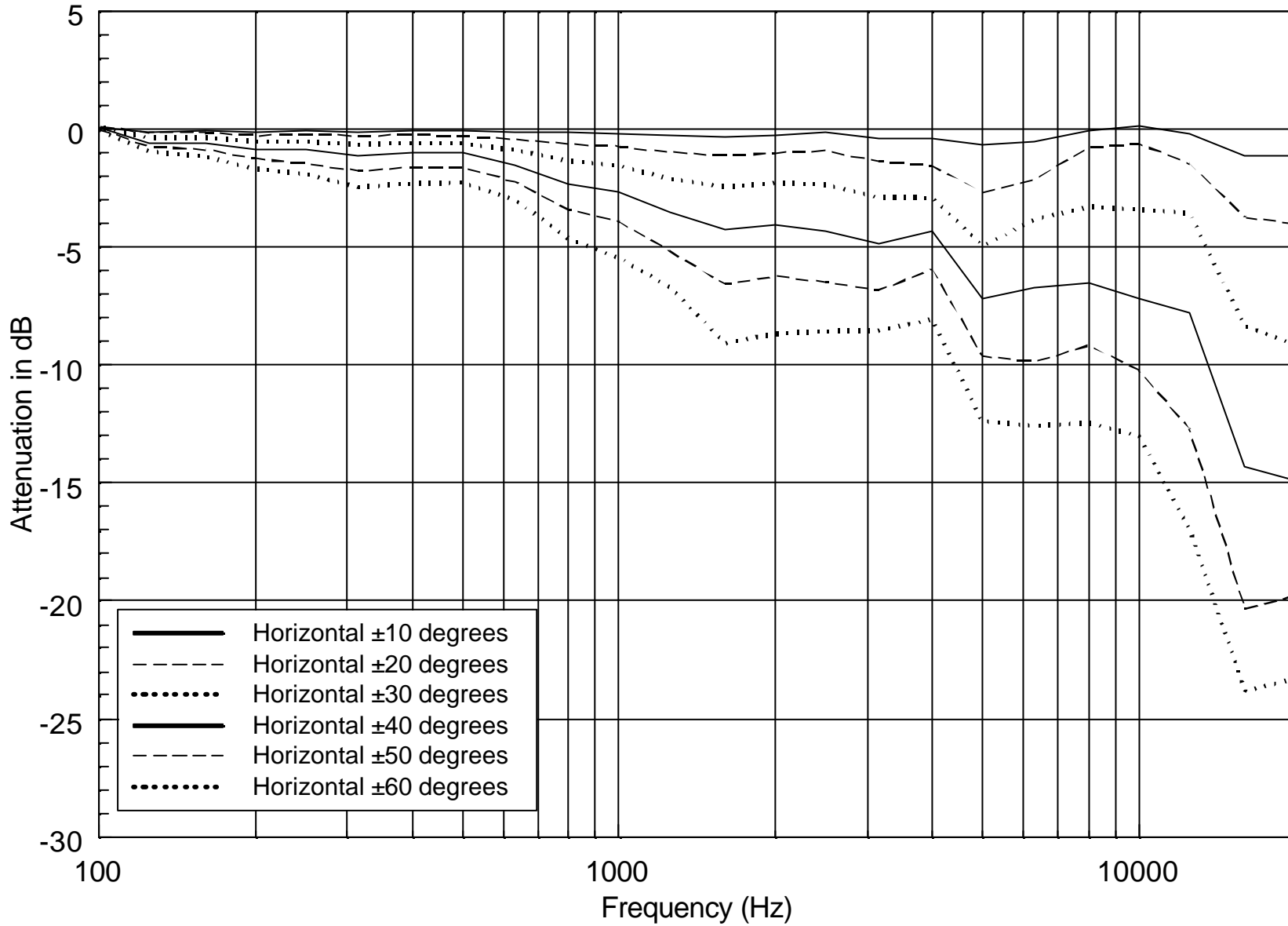

Normalized Vertical off-axis Response. Above the box

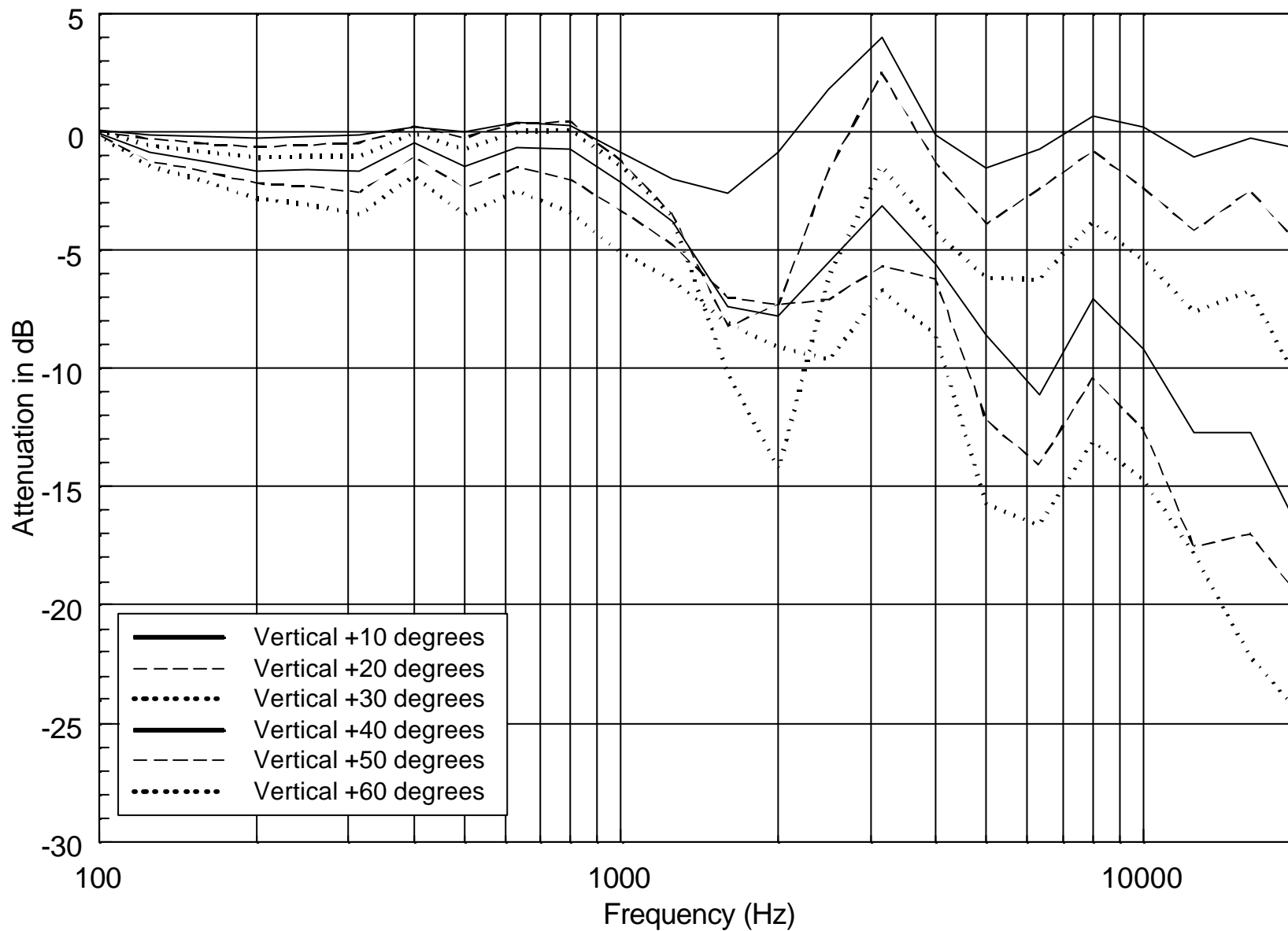

Normalized Vertical off-axis Response. Below the box

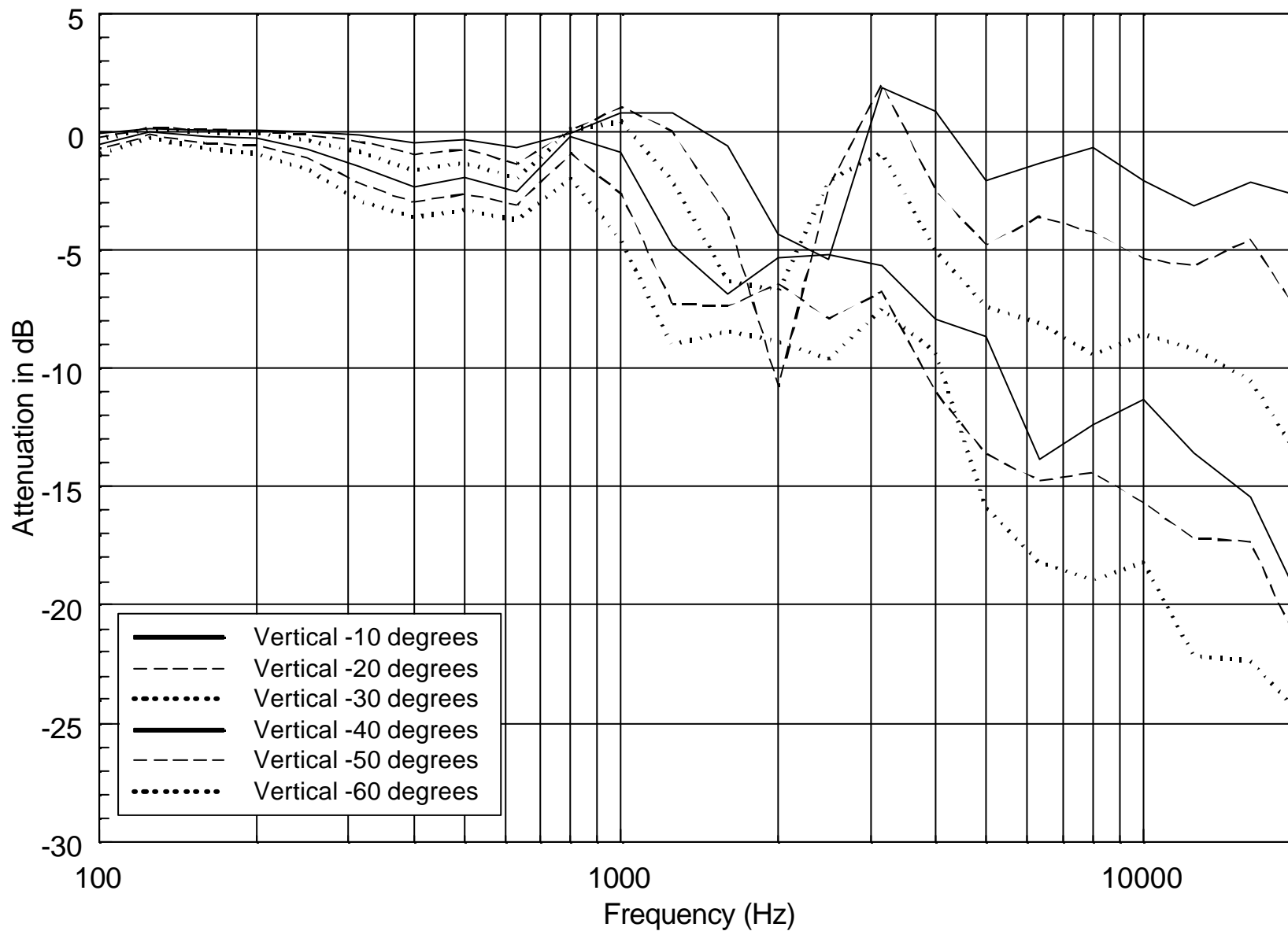

Horizontal 1/3 Octave Polars

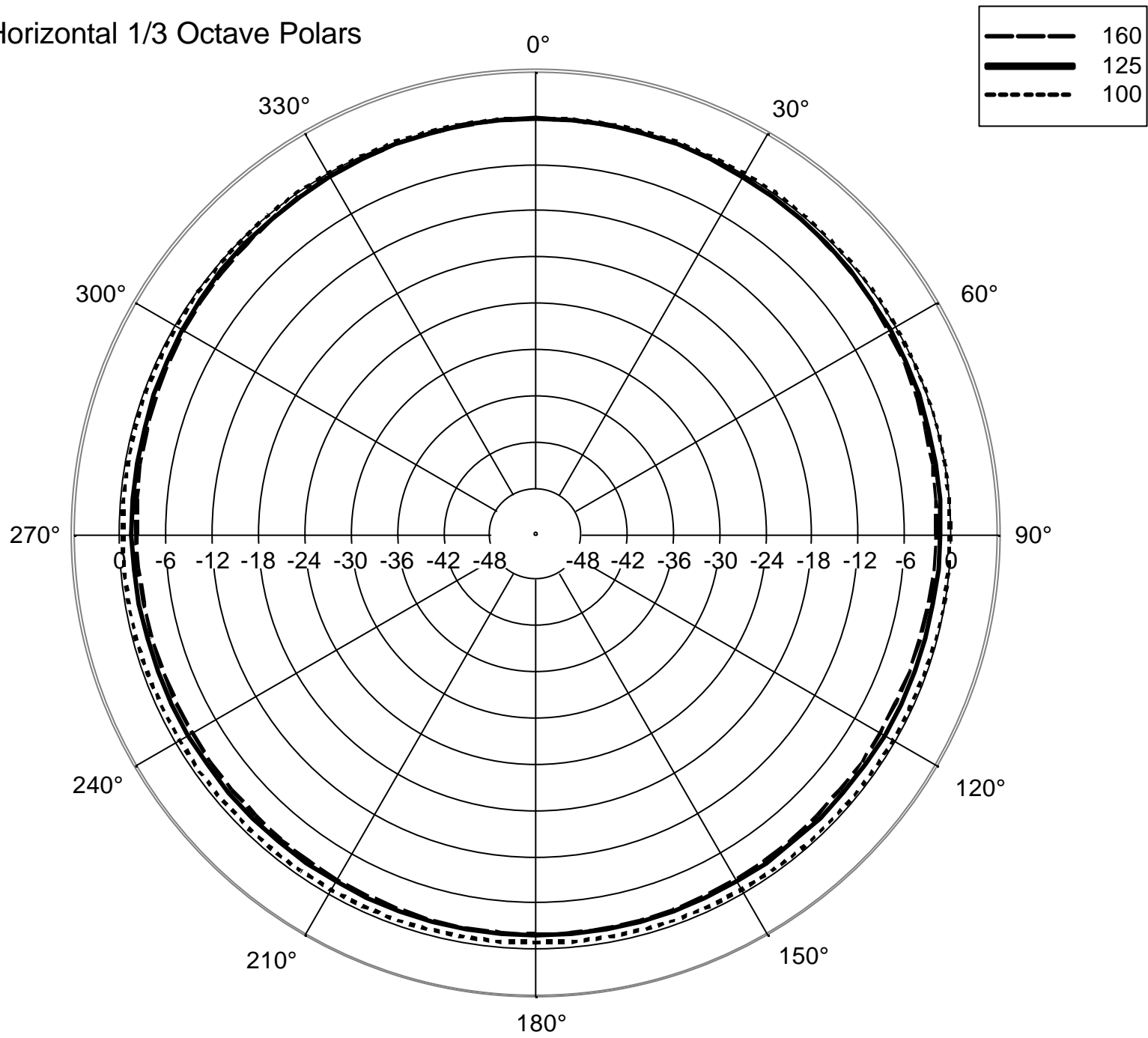

Horizontal 1/3 Octave Polars

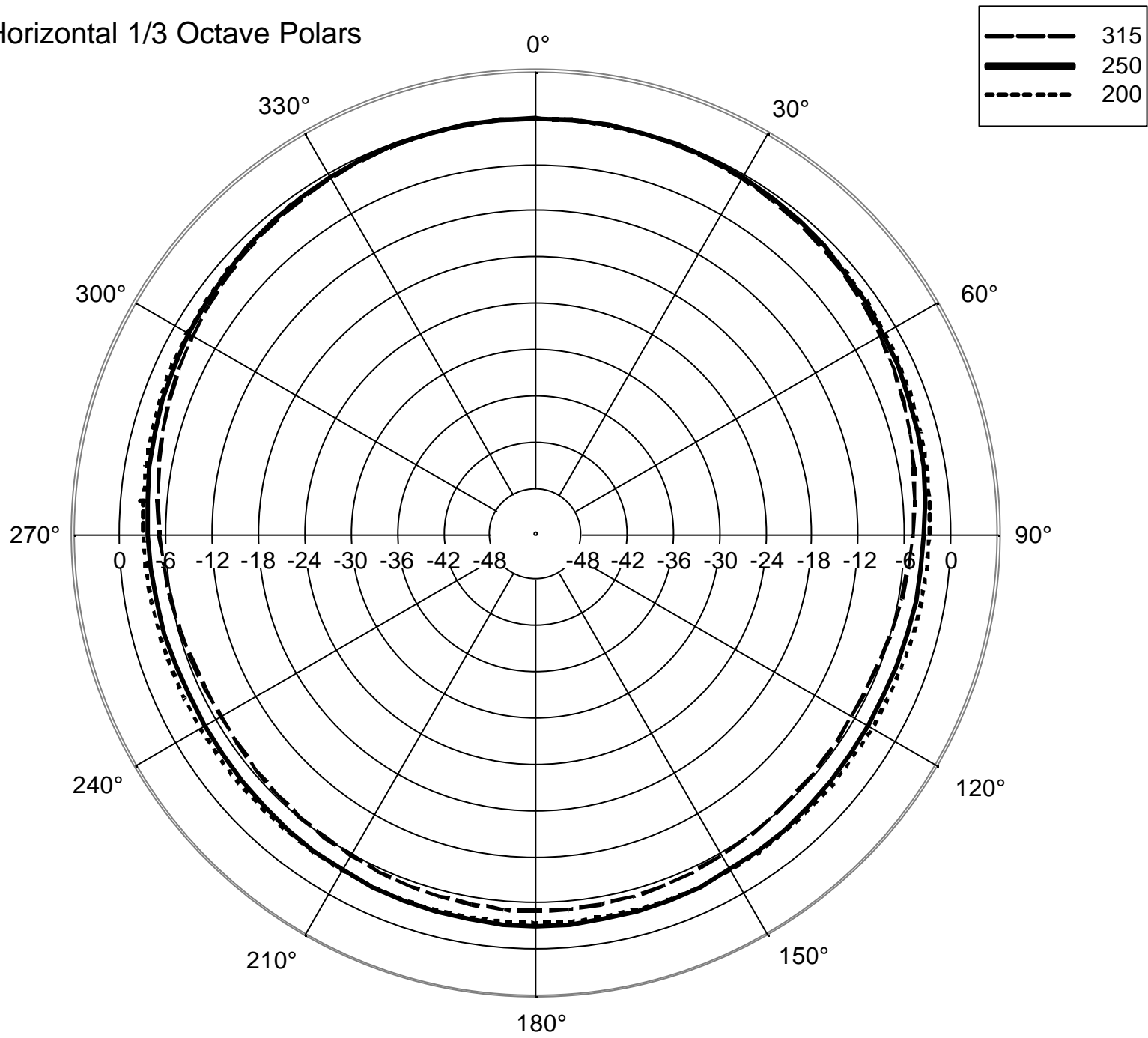

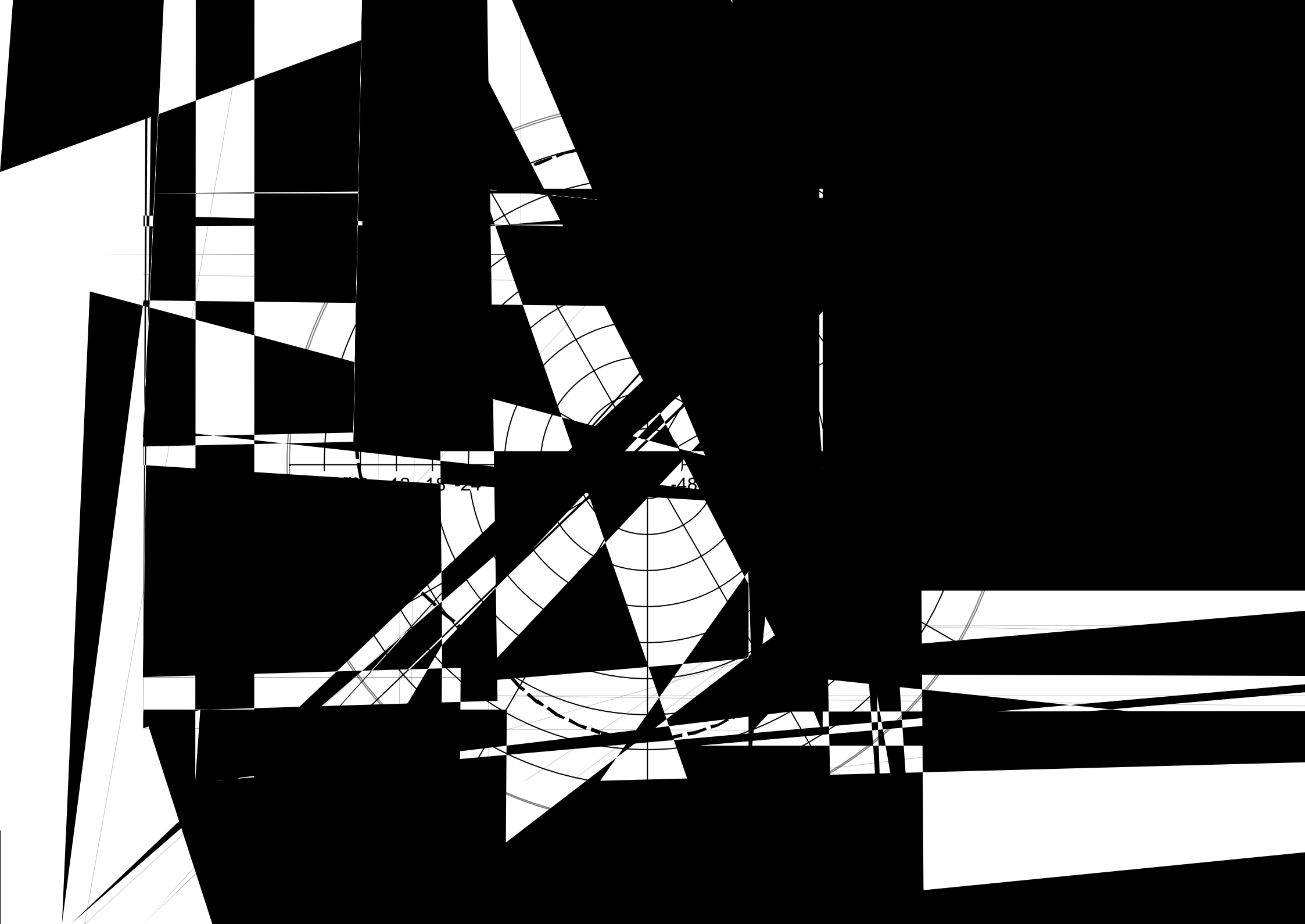

Horizontal 1/3 Octave Polars

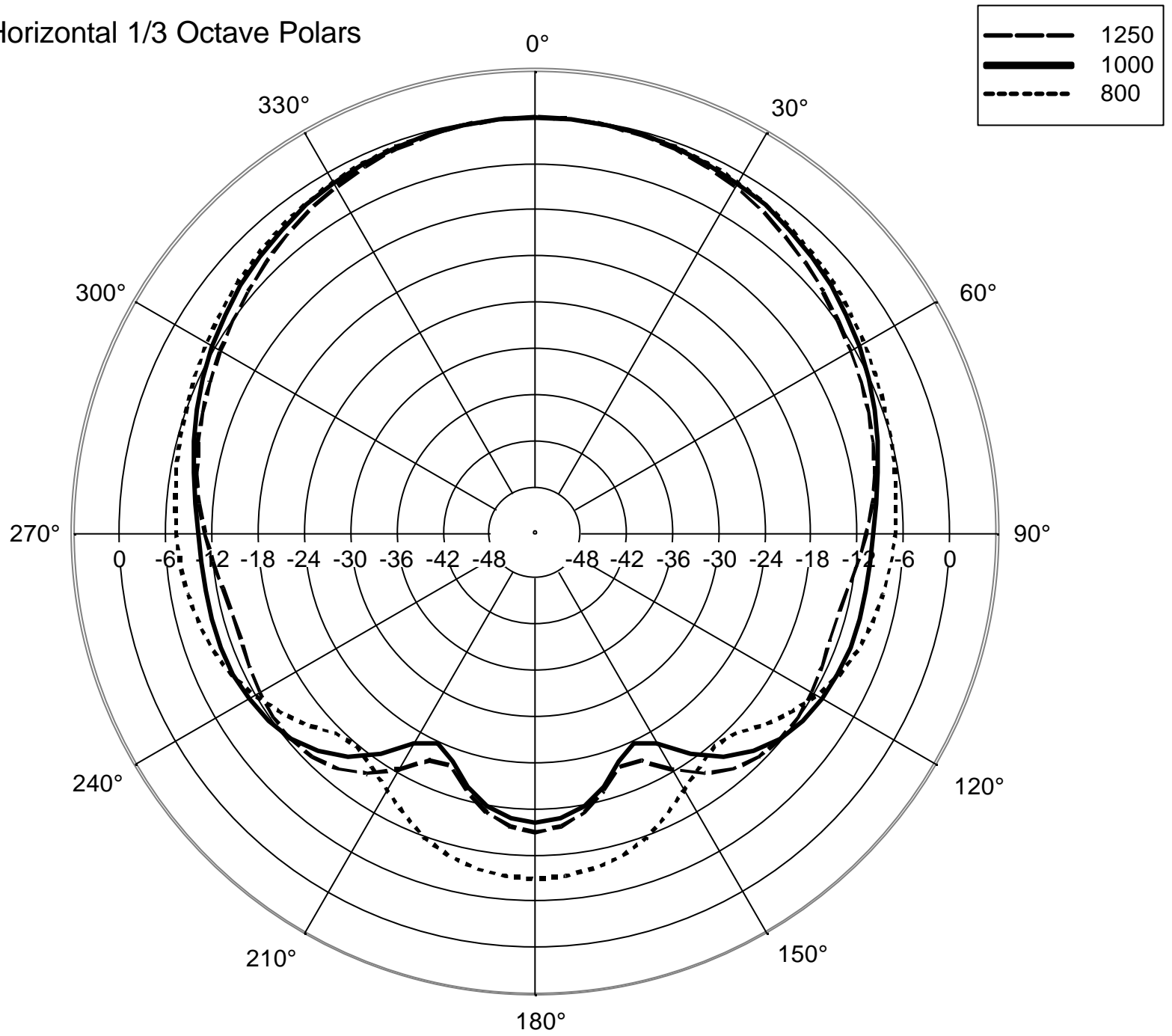

Horizontal 1/3 Octave Polars

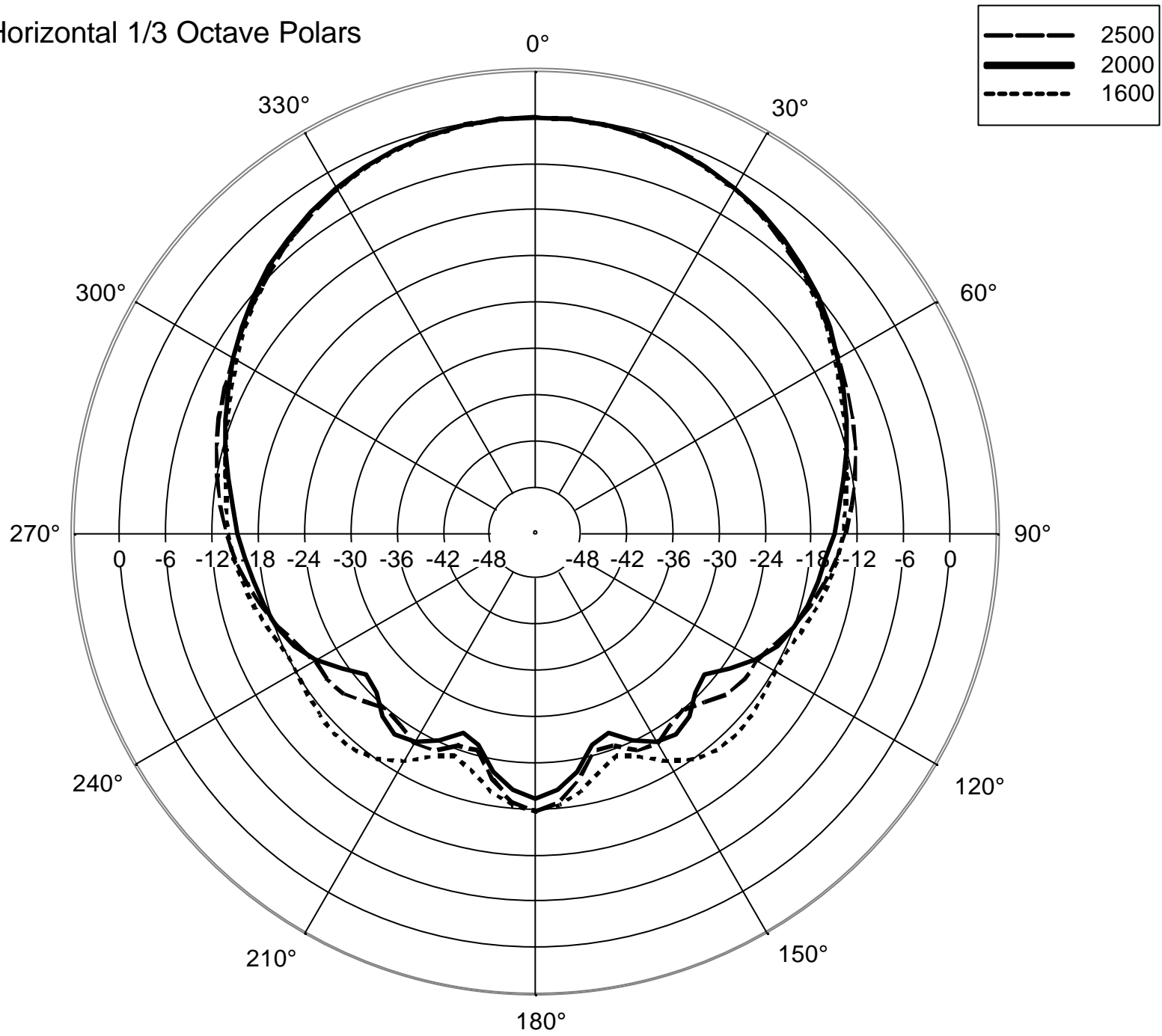

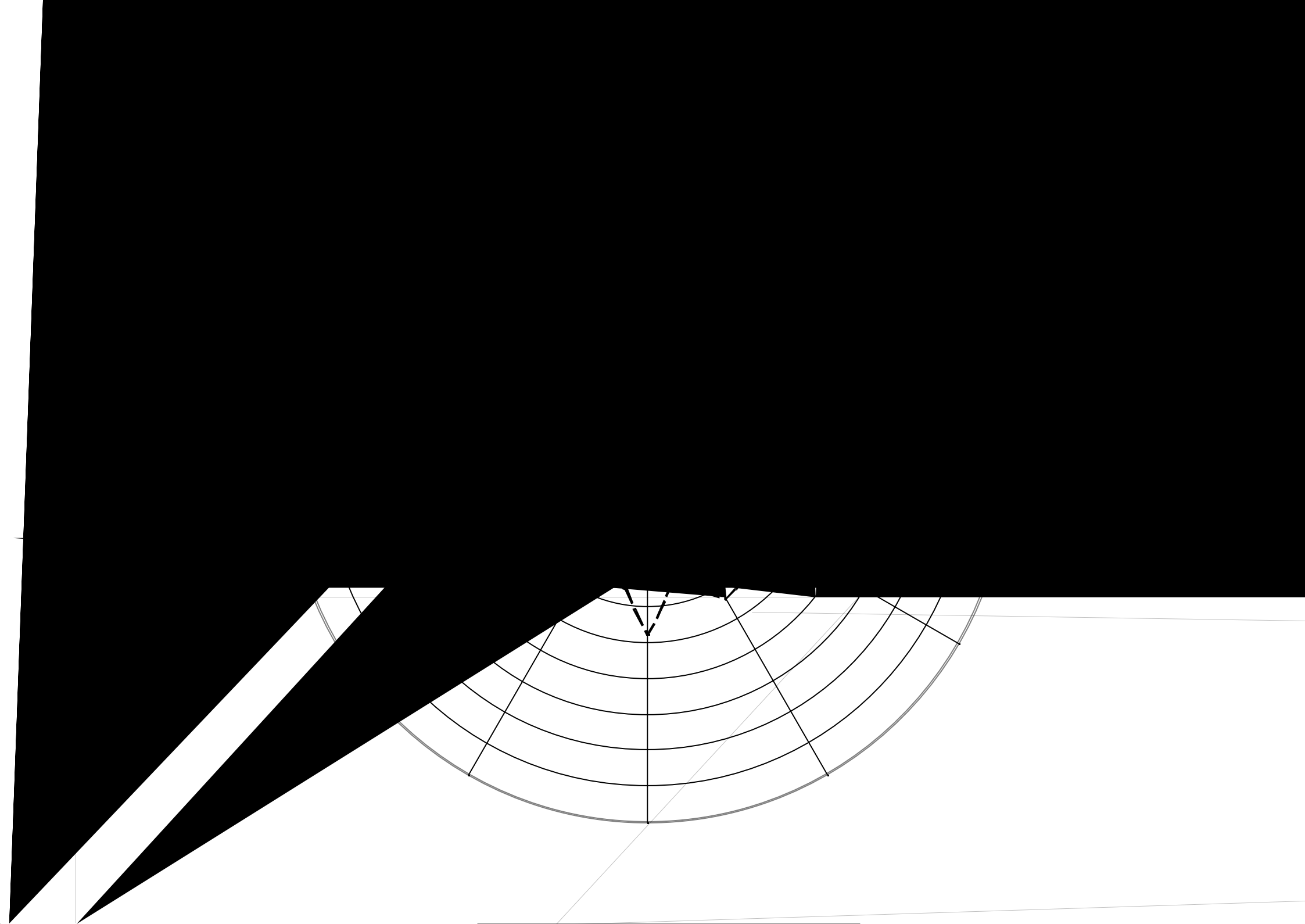

Horizontal 1/3 Octave Polars

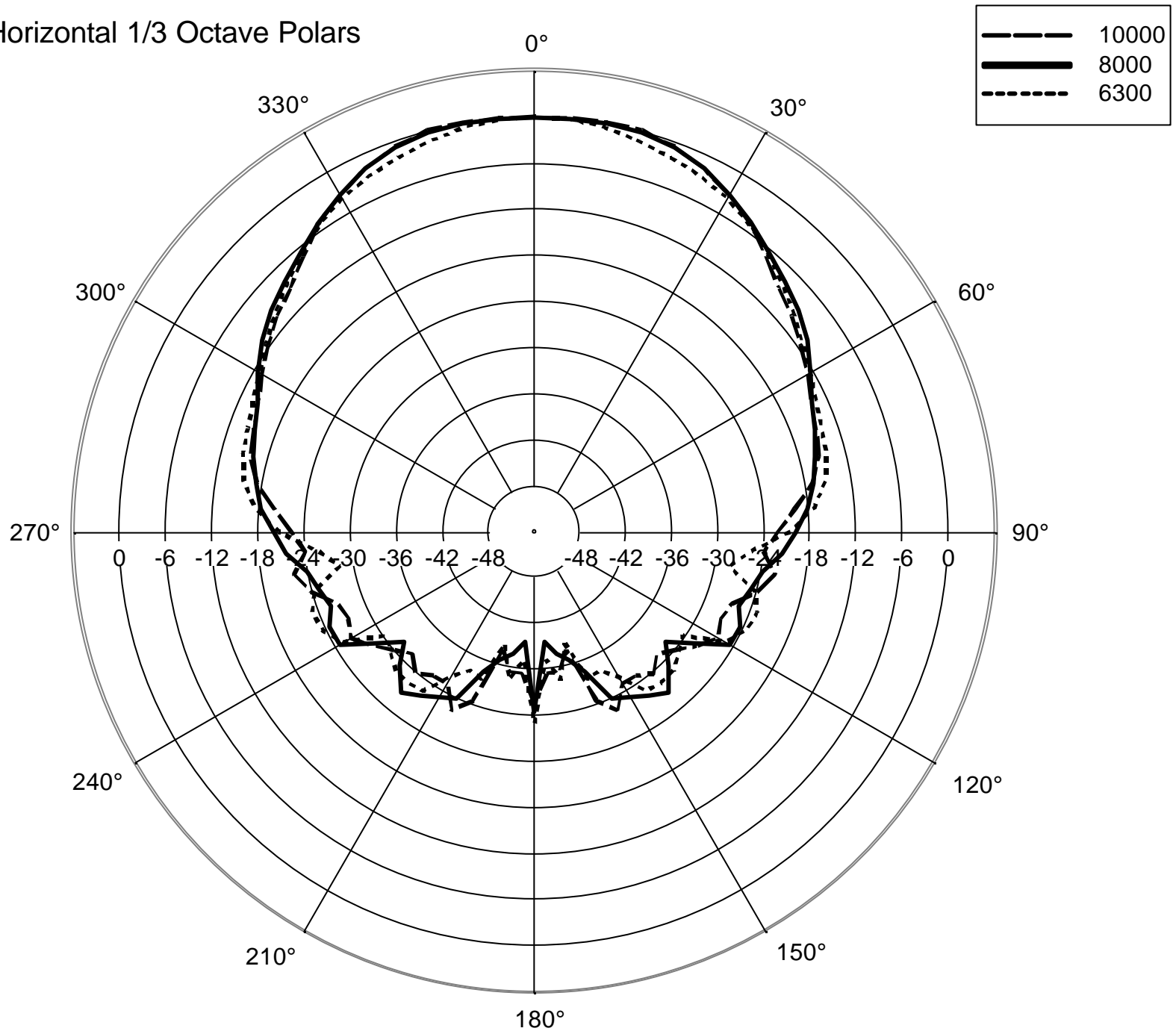

Horizontal 1/3 Octave Polars

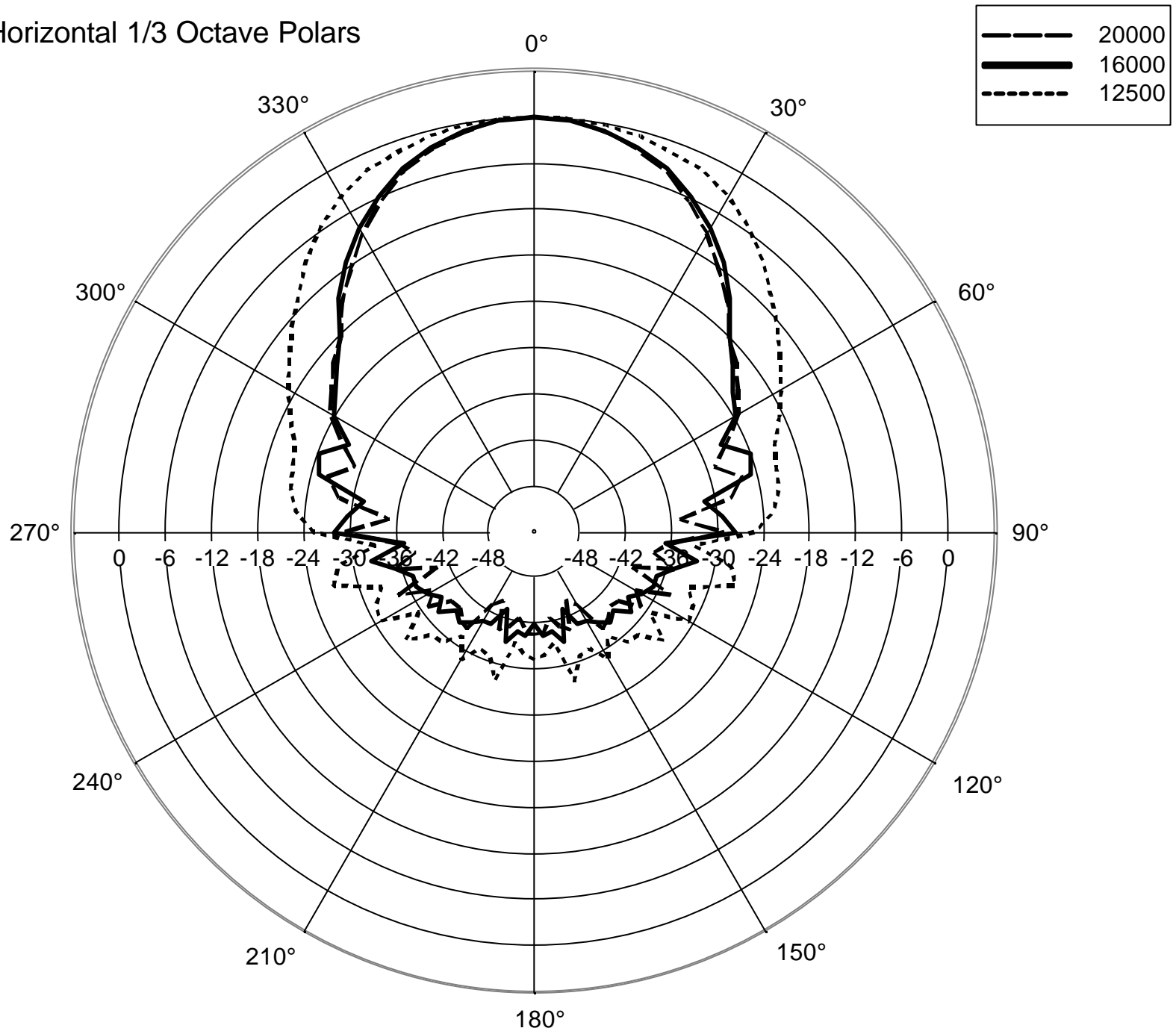

Vertical 1/3 Octave Polars

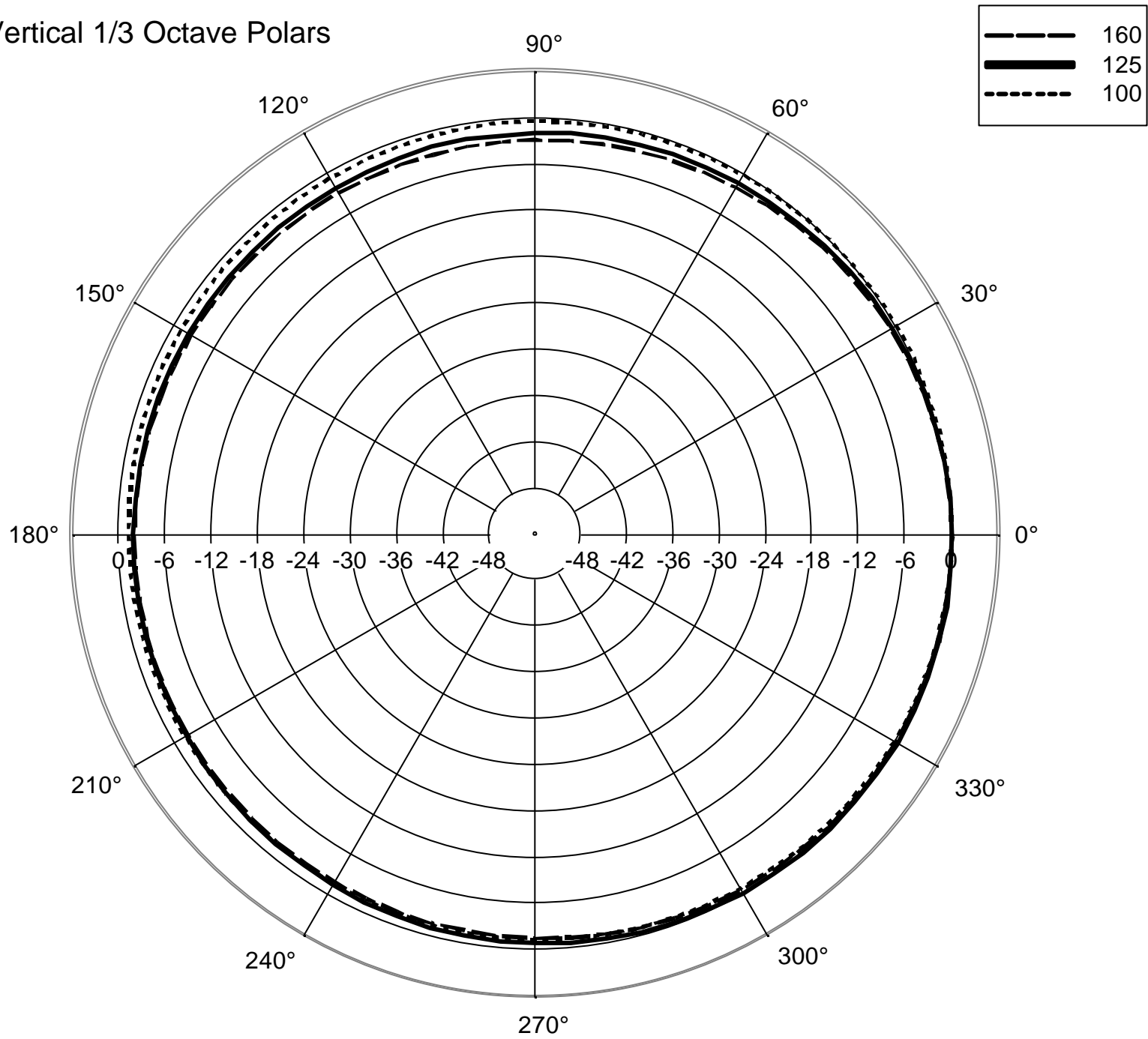

Vertical 1/3 Octave Polars

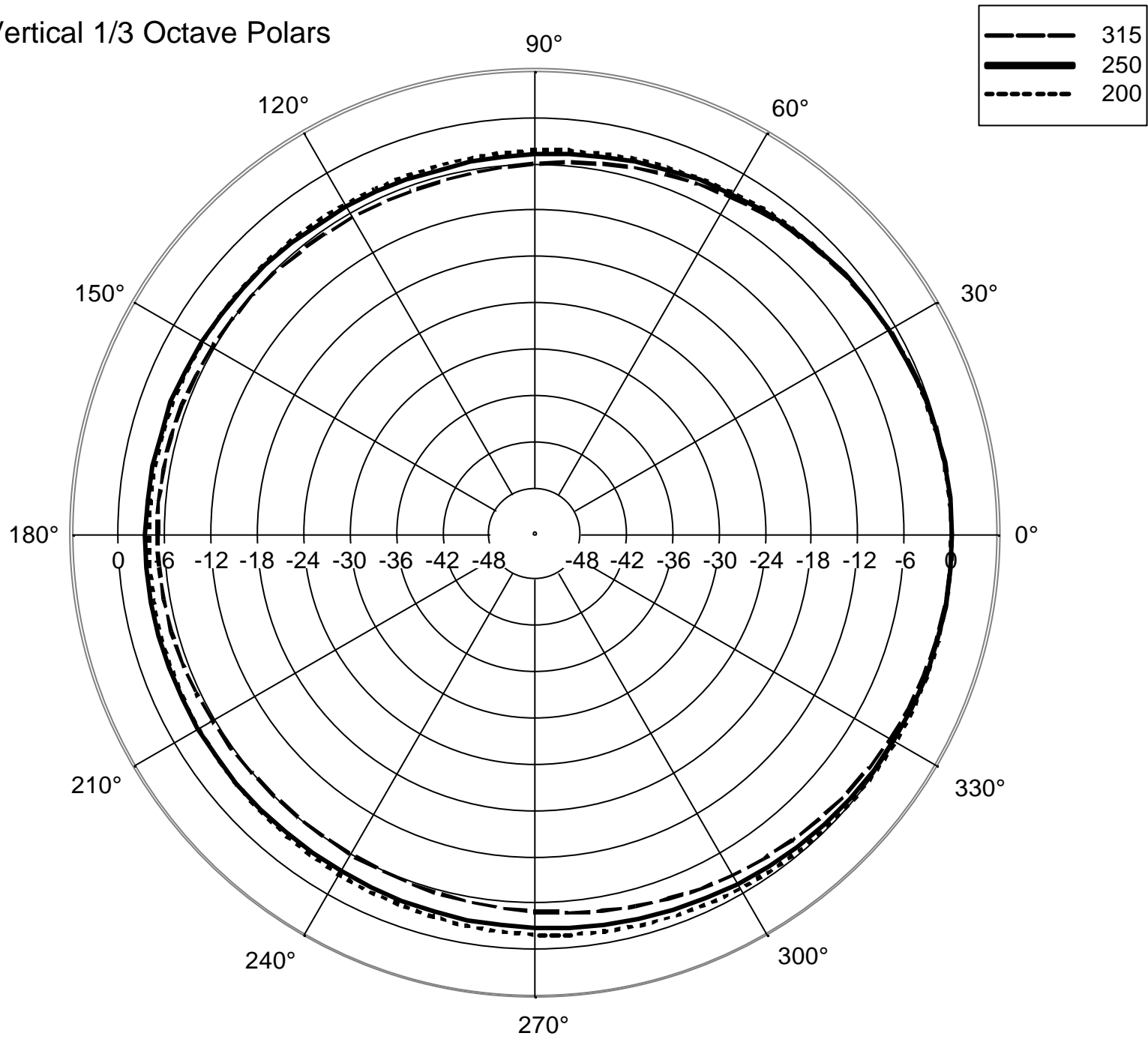

Vertical 1/3 Octave Polars

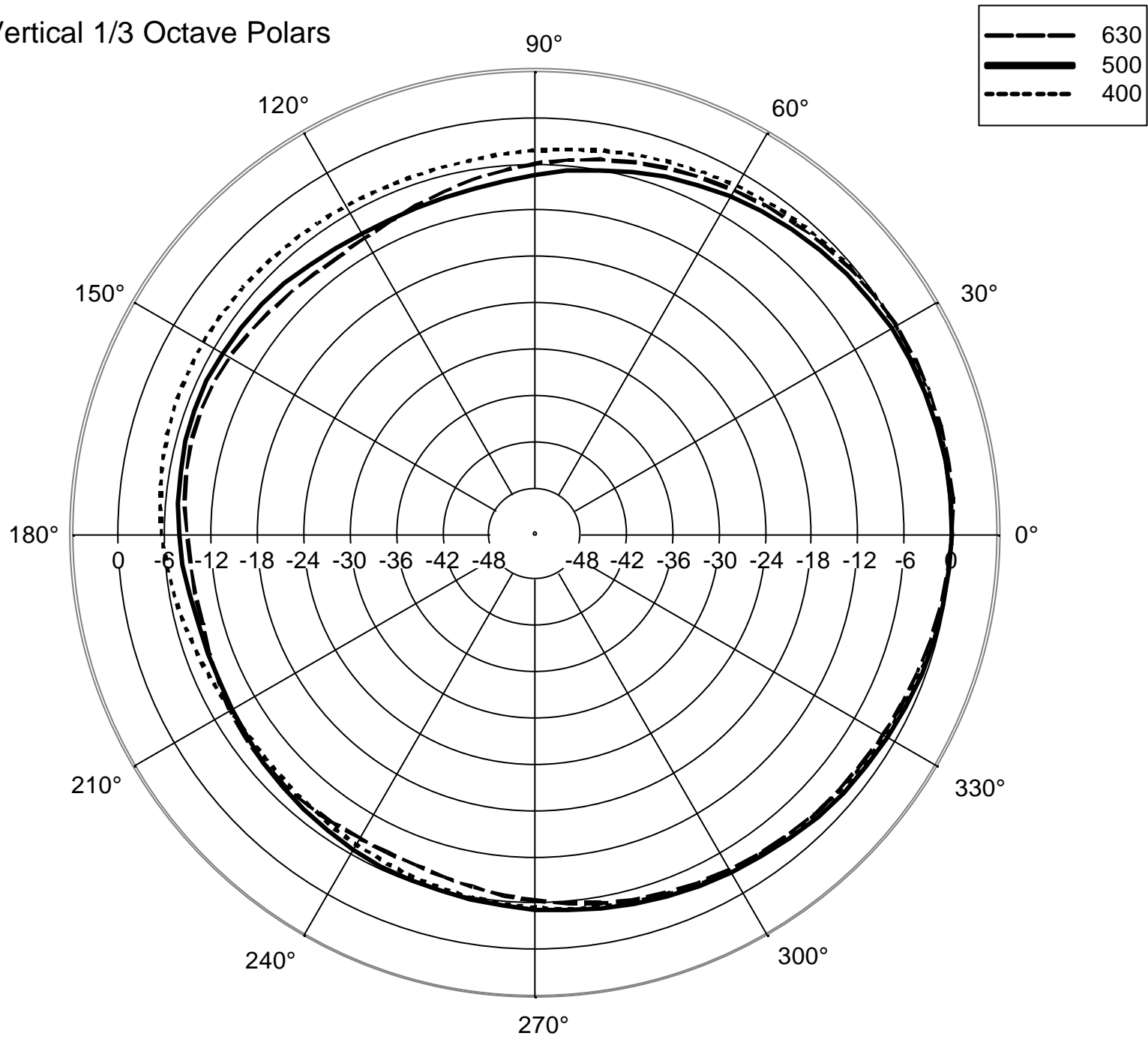

Vertical 1/3 Octave Polars

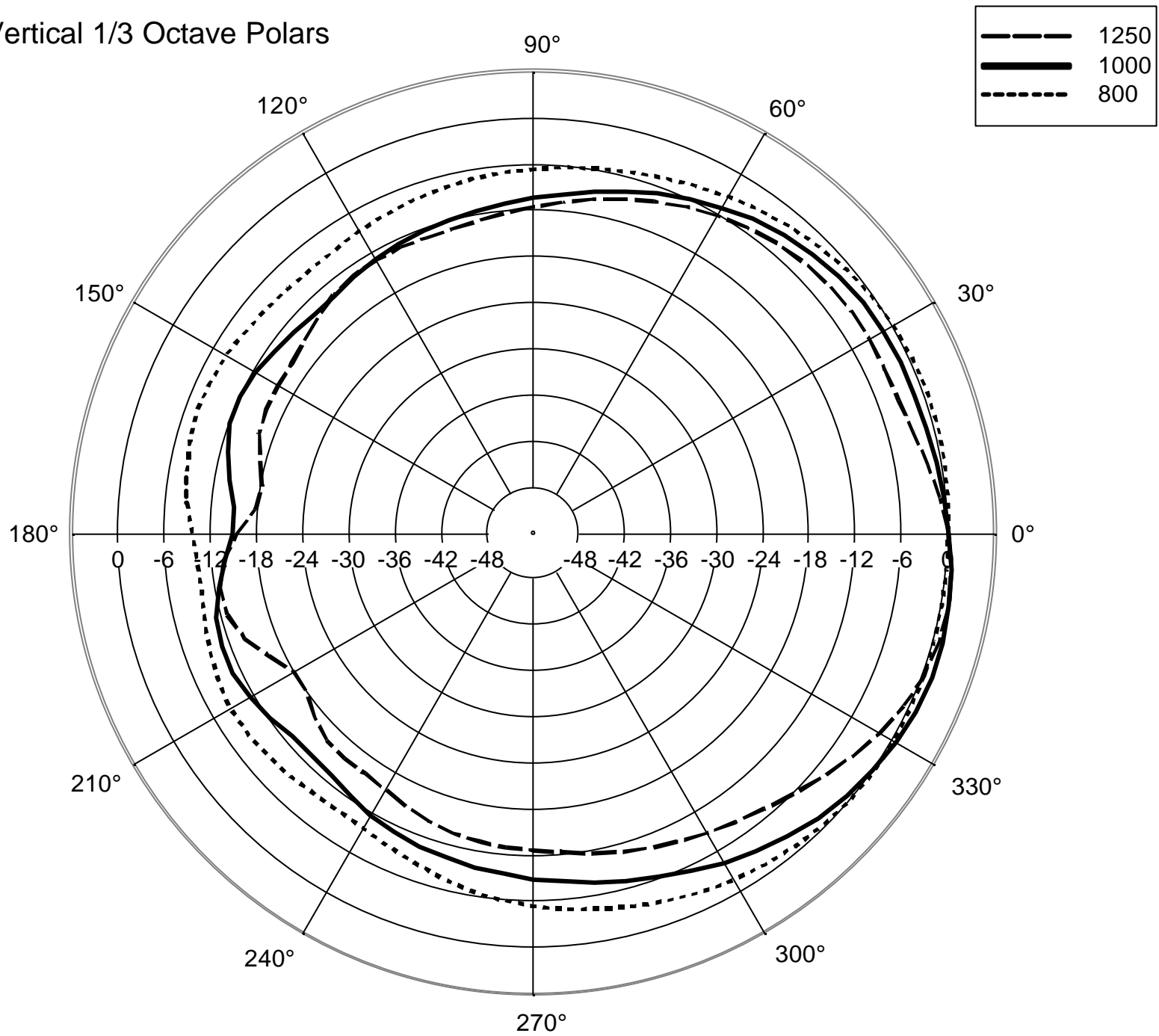

Vertical 1/3 Octave Polars

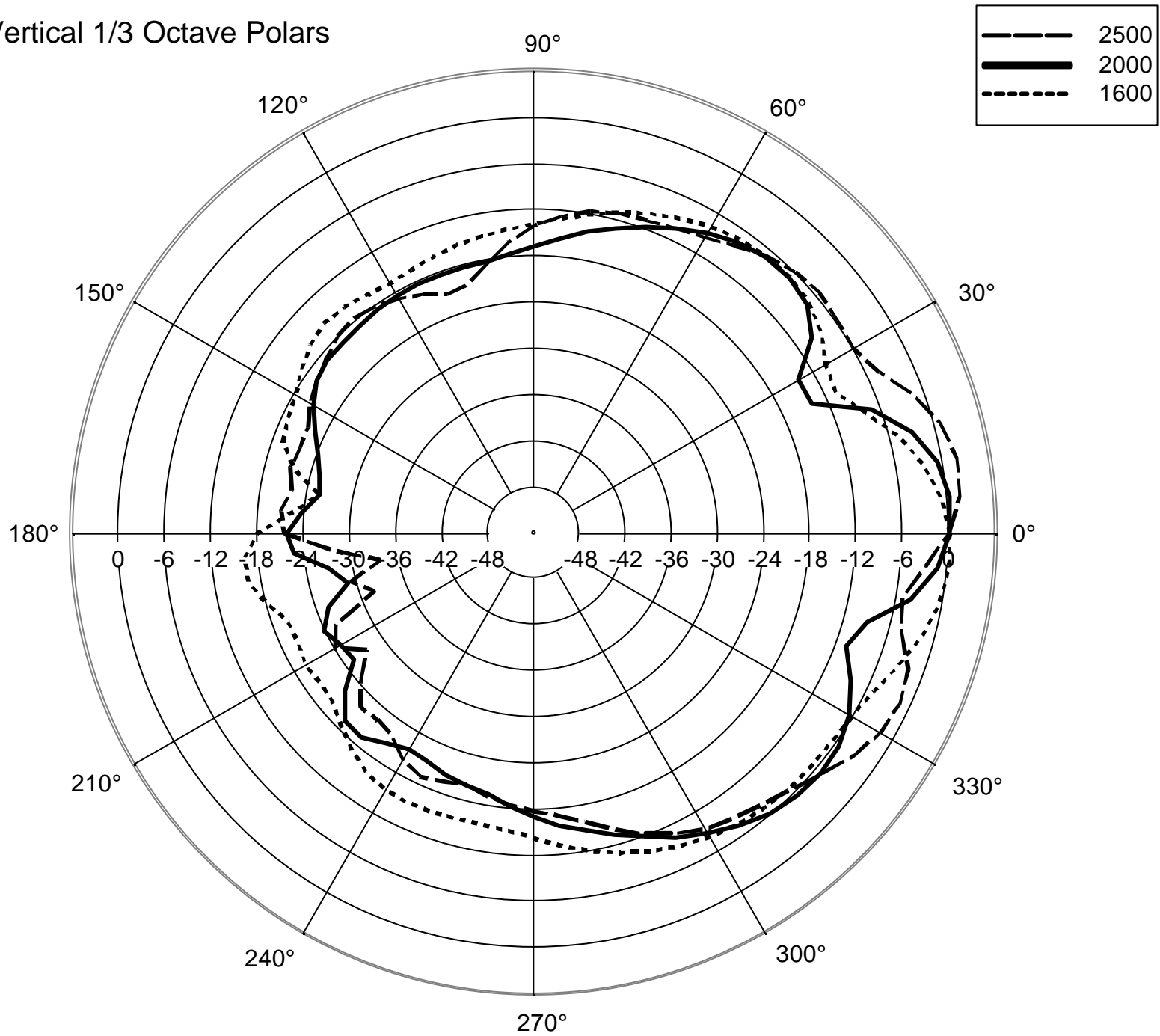

Vertical 1/3 Octave Polars

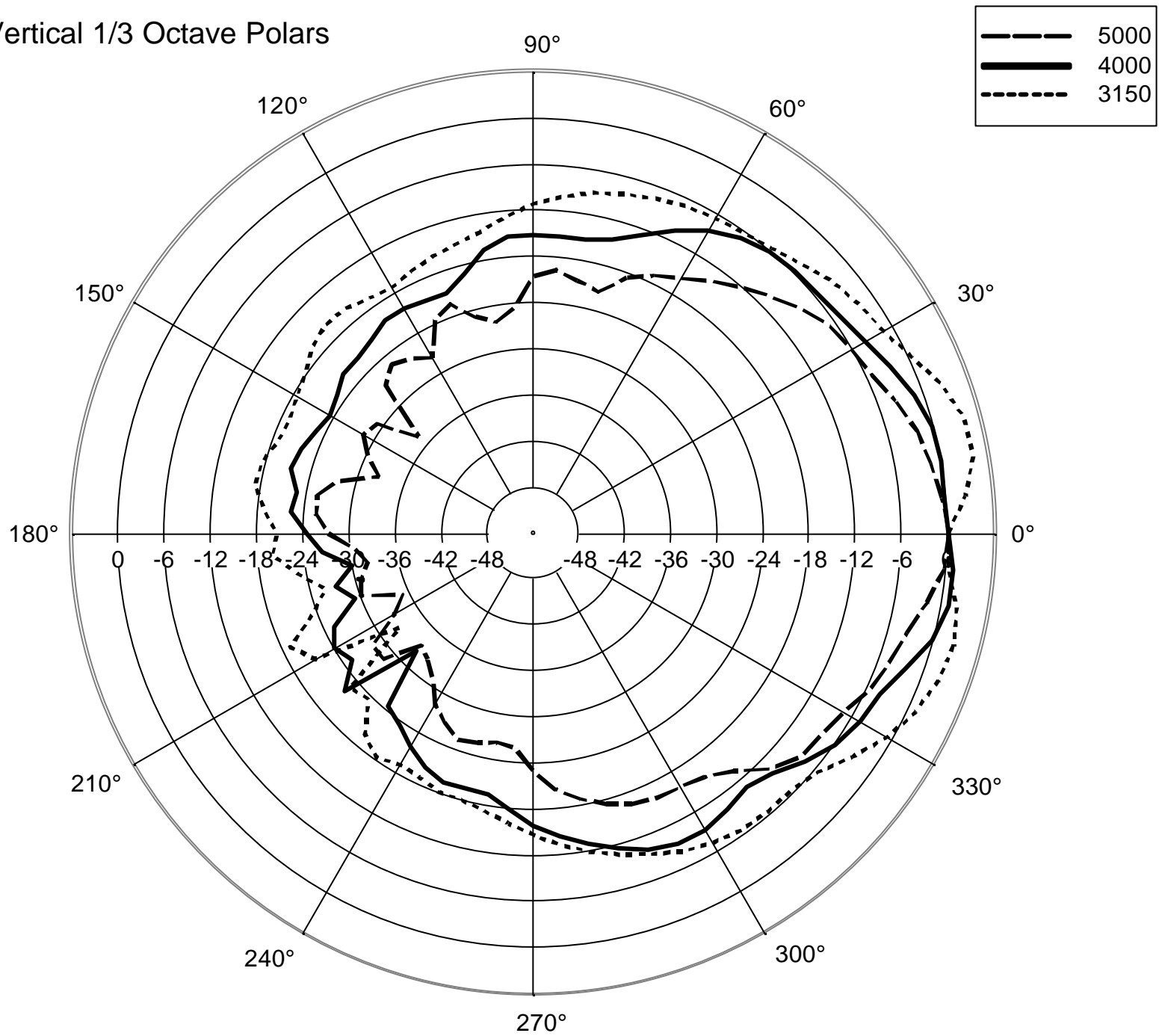

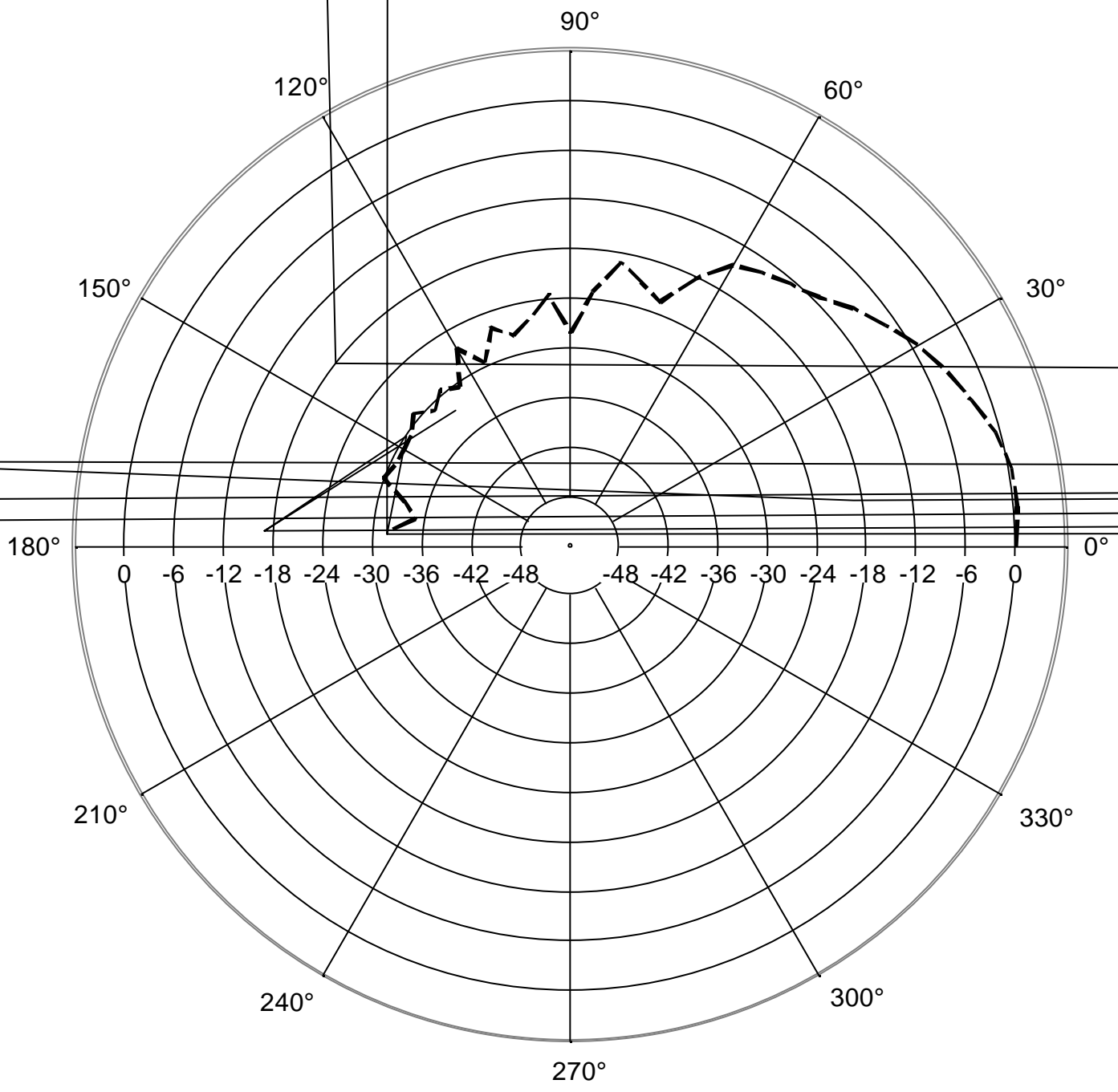

Vertical 1/3 Octave Polars

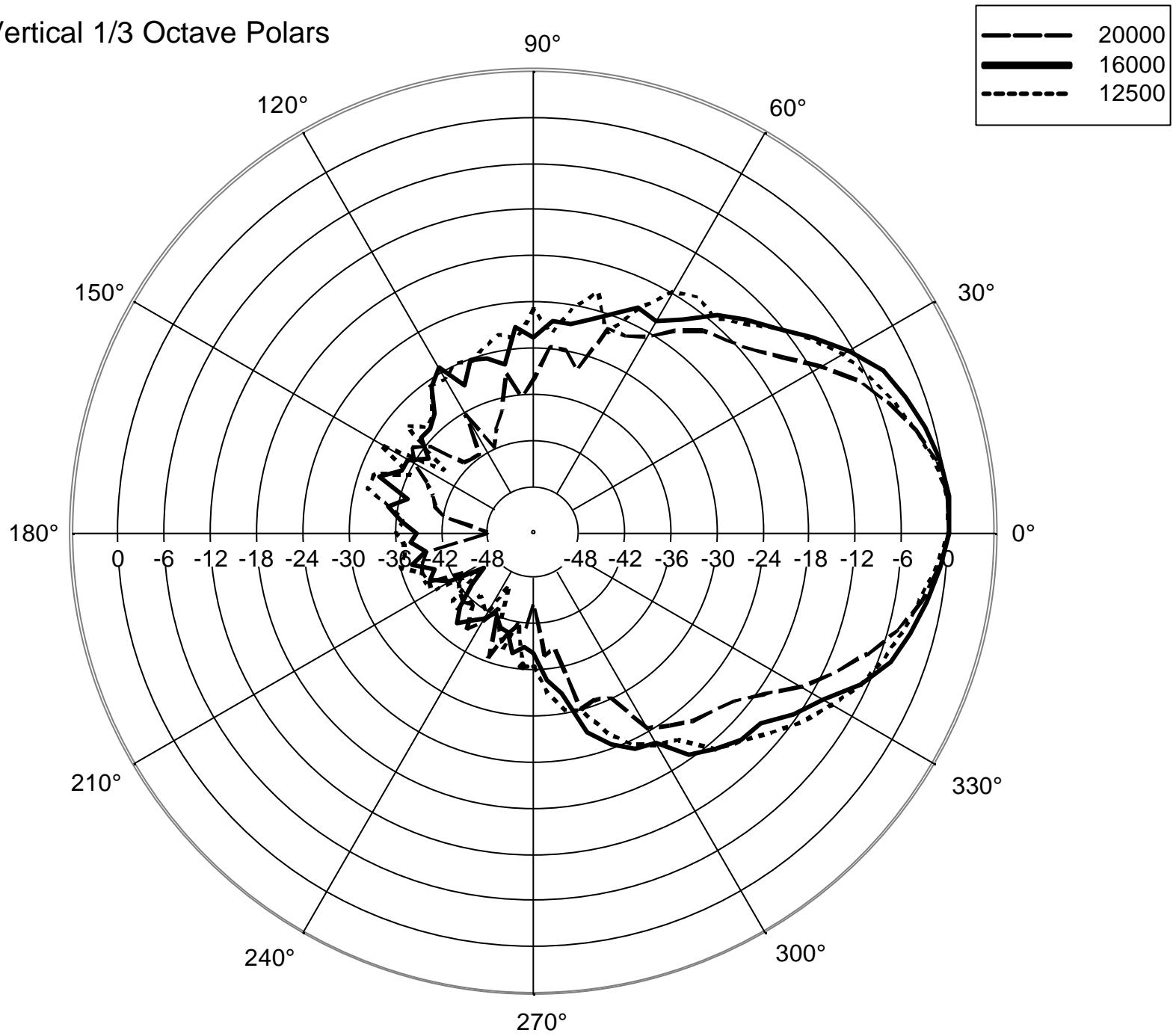

Horizontal One Octave Polars

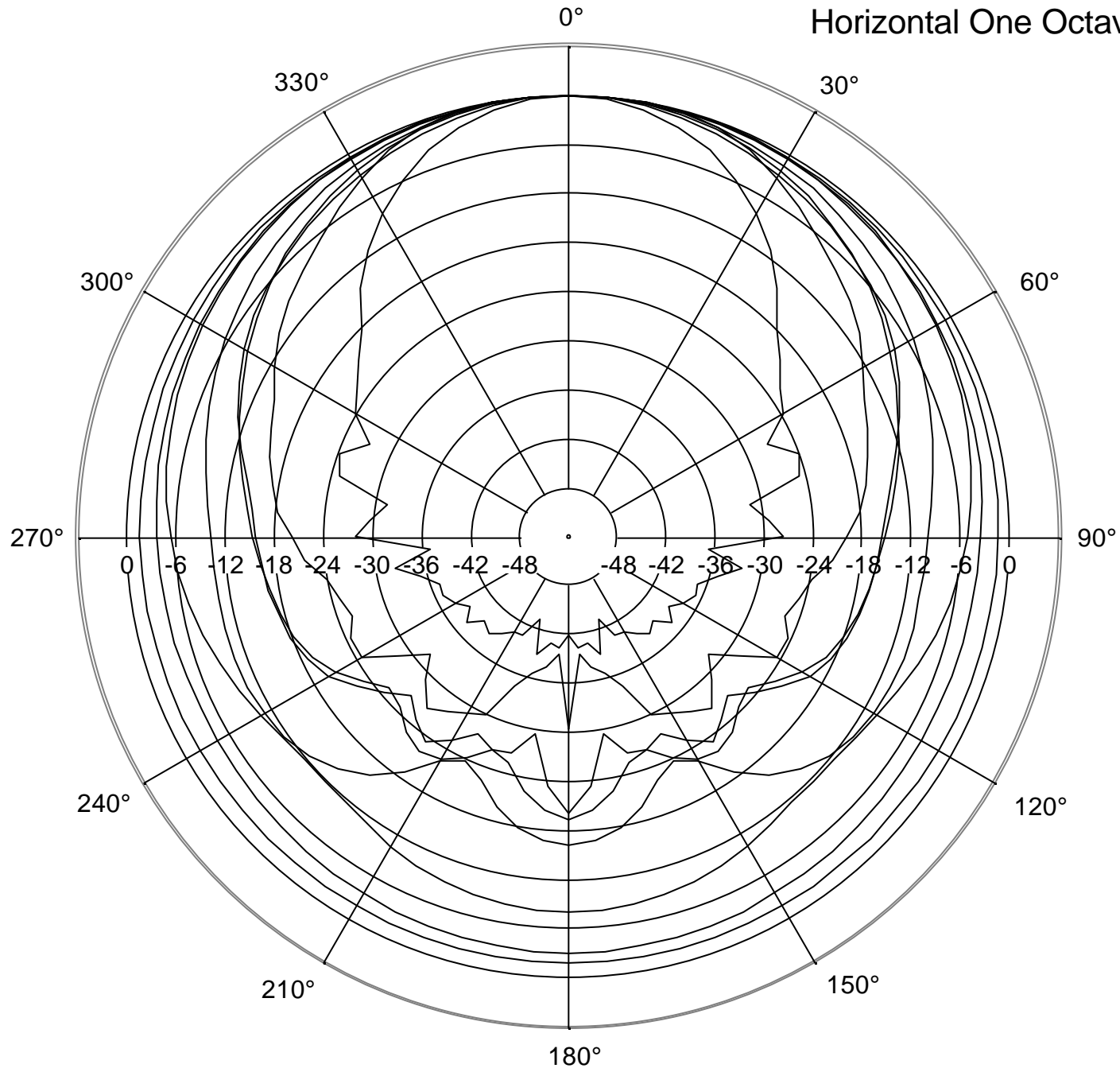

Vertical One Octave Polars

